

## DEA\_2400\_2\_Schaltschrankmontage (Artikelnummer 10277)

### SPECIFICATIONS:

ELECTRICAL	
ANTENNA TYPE	Colinear mobile whip antenna
FREQUENCY	2400 MHz band (2300–2500 MHz)
IMPEDANCE	Nom. 50 $\Omega$
POLARISATION	Vertical
GAIN	2 dB (acc. to EIA RS-329)
BANDWIDTH	$\geq$ 200 MHz at SWR $\leq$ 2.25
SWR	$\leq$ 2.0 at f. res.
MAX. POWER	25 watt
MECHANICAL	
MATERIALS	Whip: Black-chromed stainless steel Black-chromed brass
	Mount: Stainless steel Brass Environment-proof plastics
RECOMMENDED INSTALLATION TORQUE	3.5 Nm max.
CABLE	FME-cable to be ordered separately
COLOUR	Black
HEIGHT	Approx. 140 mm
WEIGHT	Approx. 34 g
MOUNTING	18 mm dia. hole

### Schildknecht AG

Internet: <http://www.schildknecht.info>

eMail: [office@schildknecht.info](mailto:office@schildknecht.info)

## INSTALLATION STEPS:

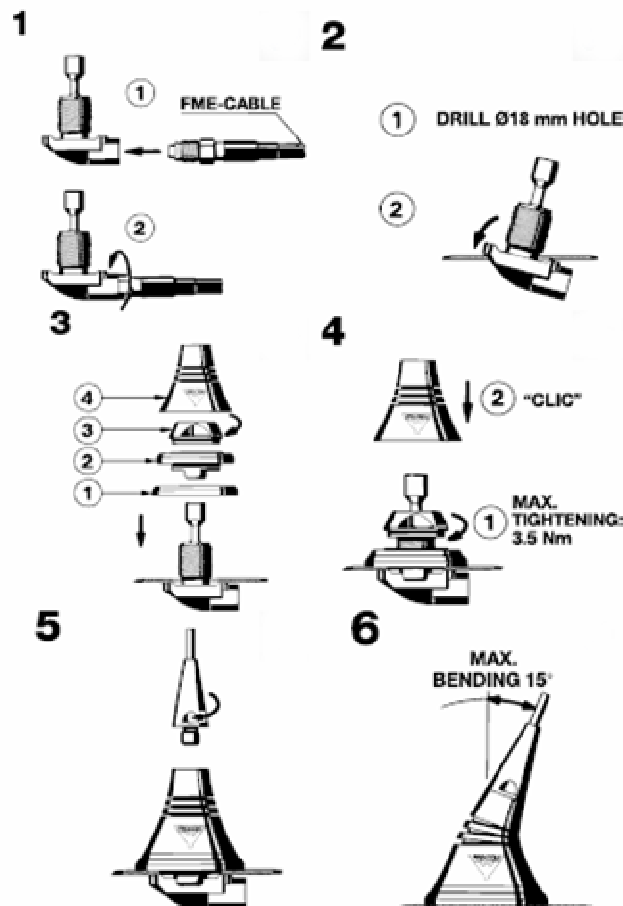

PLEASE NOTE: When tightening the revolving nut (see picture 4), special care must be taken to keep the spanner in the correct position.

**Schildknecht AG**

Internet: <http://www.schildknecht.info>

eMail: [office@schildknecht.info](mailto:office@schildknecht.info)